

**Rural
Municipality of
Municipalité
Rurale de**



TACHÉ

Box/C.P. 100
Lorette, Manitoba R0A 0Y0

Office of the Chief Administrative Officer
Bureau du Directeur Générale

Tel.: 878-3321
Fax: 878-9977
E-mail: info@rmtache.ca

January, 2013

RURAL MAIL BOX SPECIFICATIONS

The following specifications regarding rural mail boxes along municipal roads are the minimum standards required for mail delivery, road maintenance and general safety of the travelling public.

Did you know that Canada Post provides guidelines for establishing rural mail boxes? A brochure that is published by Canada Post is available at the Municipal Office which you can refer to for additional information.

Rural mailboxes may not be correctly located or sufficiently strong enough to withstand normal snowplowing operations, or may have deteriorated to the condition where they are not capable of withstanding the weight of snow thrown up by normal snowplowing operations.

Rural Mailboxes should be along the right hand side of the road in the direction the mail contractor travels and delivers along the route. The post for the mailbox should be at the rounding of the shoulder area so that the opening of the mailbox is at the outside edge of the shoulder. Mail boxes should be installed on a cantilevered arm that is a minimum of 24 inches in length and extends from the post. The bottom of the mail box should be at 42 inches above the road surface. No mailbox post should be so massive as to constitute an unnecessary hazard to a vehicle leaving the travelled portion of the road and coming in collision with the installation. Wooden posts should not exceed 4" in dimension and metal posts should not exceed 2" in dimension.

A drawing of a properly installed mail box is enclosed for your reference.

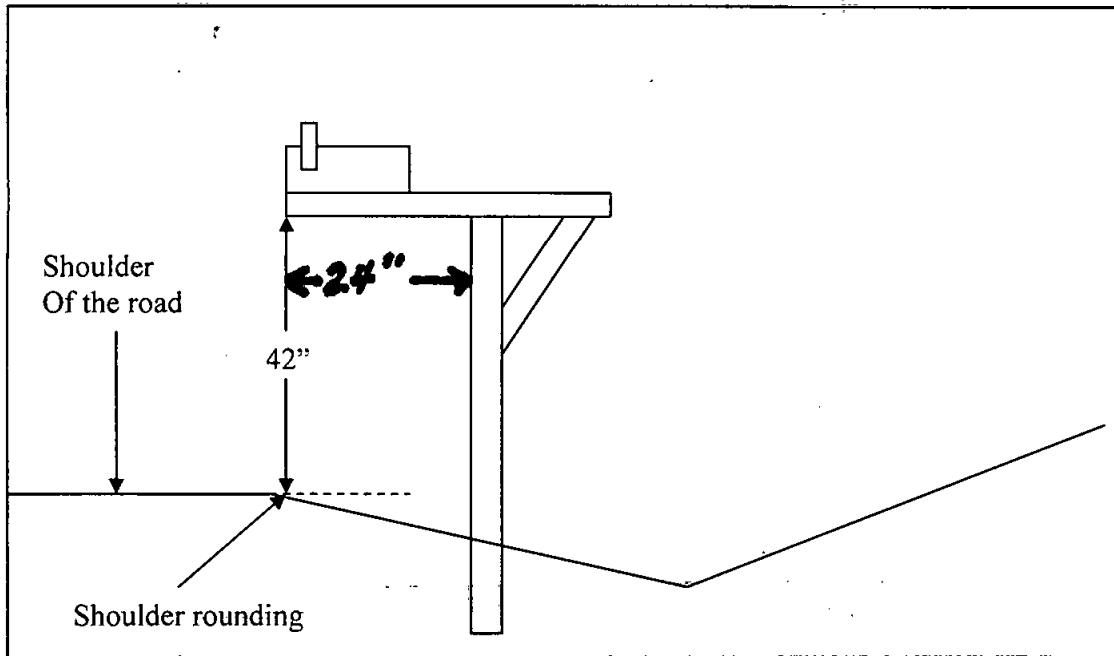

Snowplow operators are instructed to plow the road shoulder as closely as possible to the mailbox post in order to clear the snow off the shoulder. On occasion the clearance distance between the wing of the snow plow and the mail box post is misjudged and damage is caused to the mailbox or post. Such damage is readily identified and logged by the Public Works Department. The Municipality shall as a courtesy and without acknowledging liability whatsoever, repair the damage at its own expense including a standard mailbox and or post if repair is not feasible to the one that was damaged, **if the mailbox and post meet the required standard**. Repairs will be done when road conditions improve and are convenient for a work crew to attend the property.

The Municipality will not be responsible for damage resulting from snow clearing or road maintenance to any mail boxes along municipal roads if they are not upgraded to the proper standard. If you do upgrade your mail box and your mailbox is damaged by municipal road equipment, the Municipality will undertake the necessary repairs to your mail box as stated above.

Rural mail box owners should visually inspect their mail box annually before freeze up to ensure the box is secure to the post and that the post if wooden is not rotten at ground level.

Please ensure your mailbox meets the requirements for placement on municipal roads.